

DINION IP starlight 8000 MP

www.boschsecurity.com



BOSCH

Invented for life



- ▶ Remarkable low-light performance (0.0121 lx)
- ▶ 5MP high detail at fast speeds (30 fps)
- ▶ Low network strain and storage costs
- ▶ Outstanding wide dynamic range (97+16 dB)

The DINION IP starlight 8000 MP offers a new standard in round-the-clock video surveillance. Regardless of lighting conditions, time-of-day or object movement, the camera delivers relevant IP video 24/7. Capturing images at 5 megapixel resolution even under extreme low-light conditions, it gives amazing images in fine detail. The camera produces multi-megapixel full-color video in near darkness, and delivers detailed monochrome images where other cameras show no image at all.

System overview

Advanced image processing techniques take the DINION IP starlight 8000 MP to the next level. Intelligent Video Analysis (IVA) tracks and focuses on relevant situations and adds sense and structure to stored video, allowing you to quickly retrieve the correct data.

Intelligent Auto Exposure (iAE) gives superb front and back light compensation, providing the perfect picture every time.

Intelligent Dynamic Noise Reduction (iDNR) saves bitrate at the source and only uses bandwidth when needed. This results in up to 50% less bitrate which significantly reduces storage costs and network strain without compromising on video quality.

Functions

Exceptional low-light performance

The latest sensor technology, combined with the sophisticated noise suppression, results in a sensitivity of 0.0121 lx at full 5MP resolution in color and even 0.00825 lx at 1080p resolution. The low-light performance is so good that the camera continues to provide excellent color performance even with a minimum of ambient light.

Measured dynamic range

The dynamic range of the camera is outstanding and is obvious in real-world performance comparisons – 97 dB wide dynamic range for 5MP mode (plus an extra 16 dB when combined with intelligent Auto Exposure).

The actual dynamic range of the camera is measured using Opto-Electronic Conversion Function (OECF) analysis with a standardized test chart based on ISO standards. This method provides more realistic and verifiable results in comparison with the theoretical approximations sometimes used.

Intelligent Video Analysis

After only 20 minutes you can miss 90% of the activity on a screen. Intelligent Video Analysis (IVA) assists by alerting you when predefined alarms are triggered. By smartly combining up to 8 IVA rules, complex tasks are made easy and false alarms are reduced to a minimum. IVA also adds sense and structure to your video by adding metadata. This enables you to quickly retrieve the relevant images from hours of stored video. Metadata can also be used to deliver irrefutable forensic evidence or to optimize business processes based on people counting or crowd density information.

With IVA, our focus is to alert you when needed and help you quickly retrieve the correct data.

Intelligent Auto Exposure

Fluctuations in backlight and front light can ruin your images. To achieve the perfect picture in every situation, intelligent Auto Exposure (iAE) automatically adjusts the exposure of the camera. It offers superb front light compensation and incredible backlight compensation by automatically adapting to changing light conditions.

With iAE, our focus is to provide you with perfect exposure every time.

Intelligent Dynamic Noise Reduction

Quiet scenes with little or no movement require a lower bitrate. By intelligently distinguishing between noise and relevant information, intelligent Dynamic Noise Reduction (iDNR) reduces bitrate by up to 50%. Because noise is reduced at the source during image capture, the lower bitrate does not compromise on video quality.

iDNR adjusts spatial and temporal filtering (3DNR) based on intelligent analysis of the scene content. Motion compensated temporal filtering (MCTF) reduces motion blur normally associated with standard temporal filtering. This maintains image quality of fast moving objects while still optimizing bitrate.

With iDNR, our focus is to significantly reduce storage costs, and lessen network strain by only using bandwidth when needed.

Area-based encoding

Area-based encoding is another feature which reduces bandwidth. Compression parameters for up to eight user-definable regions can be set. This allows uninteresting regions to be highly compressed, leaving more bandwidth for important parts of the scene.

Bitrate optimized profile

The average typical optimized bitrate in kbits/s for various frame rates is shown in the table:

fps	5MP (4:3)	5MP (16:9)	1080p
30	4950	4500	1600
25	4685	4259	1514

15	3941	3583	1274
10	3351	3046	1083
5	2342	2129	757
2	1009	917	326

Selectable resolution and aspect ratio

The camera has three basic application variants that can be chosen at start-up to provide the best possible performance for typical applications:

- 5MP (16:9)
- 5MP (4:3)
- 1080p resolution

The 5MP variants can be used in applications where the highest resolution possible is required. The 1080p30 (16:9) variant is for applications that require extra sensitivity and dynamic range.

Each of these variants selects the best possible tuning parameters for the application so that you get the best performance possible from your camera.

User modes

The camera has a very intuitive user interface that allows fast and easy configuration. Nine configurable user modes are provided with the best settings for a variety of applications. Different user modes can be selected for day or night situations.

- **Indoor** – general day-to-night changes in an indoor environment without sun highlights or street lighting effects.
- **Outdoor** – general day-to-night changes in an outdoor environment with sun highlights and street lighting effects.
- **Night-optimized** – optimized for details in low light environments.
- **Low bit rate** – reduces bandwidth requirements.
- **Intelligent AE** – optimized for scenes with fluctuating front and back light caused by sunlight or other illuminated objects in the scene.
- **Vibrant** – enhanced contrast, sharpness and saturation.
- **Sports and gaming** – high-speed capture, and improved color rendition and sharpness.
- **Traffic** – for monitoring traffic movement on roads or parking lots. It can also be used in industrial applications where fast moving objects are to be monitored. Motion artifacts are minimized.
- **Retail** – improved color rendition and sharpness with reduced bandwidth requirements.

Multiple streams

The innovative multi-streaming feature delivers various H.264 streams together with an M-JPEG stream. These streams facilitate bandwidth-efficient viewing and recording, plus easy integration with third-party video management systems.

Depending on the resolution and frame rate selected for the first stream, the second stream provides a copy of the first stream or a lower resolution stream.

Stream assignments		
Application variant	Stream 1	Stream 2
5MP (16:9) @ 25/30 fps	2992 x 1680	Copy of stream 1
		SD: 768 x 432
		720p: 1280 x 720
		1080p: 1920 x 1080
		SD ROI: 768 x 432
		upright cropped: 400 x 720
		D1 4:3 cropped: 704 x 480
5MP (4:3) @ 25/30 fps	2704 x 2032	Copy of stream 1
		SD: 640 x 480
		SD ROI: 640 x 480
		upright cropped: 400 x 720
		SD dual ROI: 640 x 480
		800 x 600
		1024 x 768
1080 (16:9) @ 25/30 fps	1920 x 1080	SD: 768 x 432
		720p: 1280 x 720
		1080p: 1920 x 1080
		SD ROI: 768 x 432
		upright cropped: 400 x 720
		D1 4:3 cropped: 704 x 480
		SD dual ROI: 768 x 432

The third stream uses the I-frames of the first stream for recording; the fourth stream shows a JPEG image at a maximum of 10 Mbit/s.

Regions of interest and E-PTZ

Regions of Interest (ROI) can be user defined. The remote E-PTZ (Electronic Pan, Tilt and Zoom) controls allow you to select specific areas of the parent image. These regions produce separate streams for remote viewing and recording. These streams, together with the main stream, allow the operator to separately monitor the most interesting part of a scene while still retaining situational awareness. intelligent Tracking (iTracking) continuously analyses the scene for moving objects. If a moving object is detected, the camera automatically adjusts its settings, including field of view, to optimally capture details of the object of interest.

Easy installation

Power for the camera can be supplied via a Power-over-Ethernet compliant network cable connection. With this configuration, only a single cable connection is required to view, power, and control the camera. Using PoE makes installation easier and more cost-effective, as cameras do not require a local power source.

The camera can also be supplied with power from +12 VDC power supplies. To increase system reliability, the camera can be simultaneously connected to both PoE and +12 VDC supplies. Additionally, uninterruptible power supplies (UPS) can be used to ensure continuous operation, even during a power failure.

For trouble-free network cabling, the camera supports Auto-MDIX which allows the use of straight or cross-over cables.

Storage management

Recording management can be controlled by the Bosch Video Recording Manager (VRM) or the camera can use iSCSI targets directly without any recording software.

Edge recording

Insert a memory card into the card slot to store up to 2 TB of local alarm recording. Pre-alarm recording in RAM reduces recording bandwidth on the network, and extends the effective life of the memory card.

Cloud-based services

The camera supports time-based or alarm-based JPEG posting to four different accounts. These accounts can address FTP servers or cloud-based storage facilities (for example, Dropbox). Video clips or JPEG images can also be exported to these accounts.

Alarms can be set up to trigger an e-mail or SMS notification so you are always aware of abnormal events.

Access security

Password protection with three levels and 802.1x authentication is supported. To secure Web browser access, use HTTPS with a SSL certificate stored in the camera. The video and audio communication channels can be independently AES encrypted with 128-bit keys by installing the optional encryption site license.

Complete viewing software

There are many ways to access the camera's features: using a web browser, with the Bosch Video Management System, with the free-of-charge Bosch Video Client, with the video security mobile app, or via third-party software.

System integration

The camera conforms to the ONVIF (Open Network Video Interface Forum) Profile S specification. This guarantees interoperability between network video products regardless of manufacturer.

Third-party integrators can easily access the internal feature set of the camera for integration into large projects. Visit the Bosch Integration Partner Program (IPP) website (ipp.boschsecurity.com) for more information.

Certifications and approvals

Standards	
Emission	EN 55022 Class B (2010), +AC (2011) FCC: 47 CFR 15, class B (2012-10-1)
Immunity	EN 50130-4 (PoE, +12 VDC)* (2011) EN 50121-4 (2006), +AC: (2008)
Alarm	EN 50130-5 Class II (2011)
Safety	EN 60950-1 UL 60950-1 (2nd edition) CAN/CSA-C 22.2 No. 60950-1
Vibration	Camera with 500 g (1.1 lb) lens as per IEC 60068-2-6 (5 m/s ² , operational)
HD	SMPTE 296M-2001 (Resolution: 1280x720) SMPTE 274M-2008 (Resolution: 1920x1080)
Color representation	ITU-R BT.709
ONVIF conformance	EN 50132-5-2; IEC 62676-2-3

* Chapters 7 and 8 (mains voltage supply requirement) are not applicable to the camera. However, if the system in which this camera is used needs to comply with this standard, then any power supplies used must comply with this standard.

Region	Certification
Europe	CE
USA	UL
	FCC
Canada	CSA

Installation/configuration notes

Controls

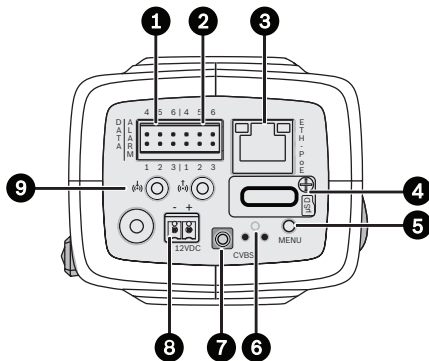

1	Data (RS485/422/232)	6	Reset button
2	Alarm in, alarm out	7	Service video out (SMB connector)
3	10/100 Base-T Fast Ethernet	8	Power supply input (12 VDC only)
4	MicroSD card slot	9	Audio in / Audio out
5	Menu button		

Dimensions

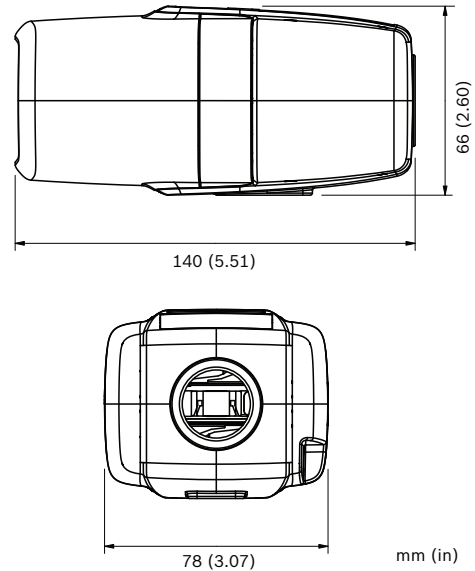

Technical specifications

Power	
Power Supply	12 VDC Power-over-Ethernet 48 VDC nominal
Current Consumption	750 mA (12 VDC) 200 mA (PoE 48 VDC)
Power Consumption	9 W
PoE	IEEE 802.3af (802.3at Type 1) Class 3
Sensor	
Type	1/1.8" CMOS
Total sensor pixels	6.1 MP
Video performance - Dynamic range	
5MP (4:3) mode	97 dB WDR (97+16 dB with iAE)
5MP (16:9) mode	97 dB WDR (97+16 dB with iAE)
1080p mode	103 dB WDR (103+16 dB with iAE)

Video performance – Sensitivity (3200K, 89% reflectivity, 30% IRE, F1.2)	
Color 5MP mode	0.0121 lx
Color 1080p mode	0.00825 lx
Mono 5MP mode	0.004 lx
Mono 1080p mode	0.00275 lx
Video streaming	
Video compression	H.264 (MP); M-JPEG
Streaming	Multiple configurable streams in H.264 and M-JPEG, configurable frame rate and bandwidth. Regions of Interest (ROI)
Overall IP Delay	Min. 120 ms, Max. 340 ms
GOP structure	IP, IBP, IBBP
Encoding interval	1 to 30 [25] fps
Encoder regions	Up to 8 areas with encoder quality settings per area
Video resolution	
5MP (16:9)	2992 X 1680
5MP (4:3)	2704 X 2032
1080p HD	1920 X 1080
720p HD	1280 x 720
Upright 9:16 (cropped)	400 x 720
D1 4:3 (cropped)	704 x 480
480p SD	Encoding: 704 x 480; Displayed: 854 x 480
432p SD	768 x 432
288p SD	512 x 288
240p SD	Encoding: 352 x 240; Displayed: 432 x 240
144p SD	256 x 144
Video functions	
Day/Night	Color, Monochrome, Auto
Adjustable picture settings	Contrast, Saturation, Brightness
White Balance	2500 to 10000K, 4 automatic modes (Standard, SON/SOX, Basic, Dominant color), Manual mode and Hold mode
Shutter	Automatic Electronic Shutter (AES) Fixed (selectable) Default shutter
Backlight compensation	Off, Auto, intelligent Auto Exposure (iAE)

Video functions	
Noise reduction	intelligent Dynamic Noise Reduction (iDNR) with separate temporal and spatial adjustments
Contrast enhancement	On/off
Sharpness	Sharpness enhancement level selectable
Privacy Masking	Four independent areas, fully programmable
Video Motion Analysis	Intelligent Video Analysis (IVA)
User modes	9 modes
Other functions	Image flip, Pixel counter, Video watermarking, Display stamping

Audio streaming	
Standard	G.711, 8 kHz sampling rate L16, 16 kHz sampling rate AAC-LC, 48 kHz sampling rate AAC-LC, 80 kHz sampling rate
Signal-to-Noise Ratio	>50 dB
Audio Streaming	Full-duplex / half duplex

Input/output	
Analog video out	SMB connector, CVBS (PAL/NTSC), 1 Vpp, 75 Ohm (service only)
Audio line in	1 Vrms max, 18 kOhm typical,
Audio line out	0.85 Vrms at 1.5 kOhm typical,
Audio connectors	3.5 mm mono jack
Alarm input	2 inputs
Alarm input activation	+5 VDC nominal; +40 VDC max. (DC-coupled with 50 kOhm pull-up resistor to +3.3 VDC) (< 0.5 V is low; > 1.4 V is high)
Alarm output	1 output
Alarm output voltage	30 VAC or +40 VDC max. Maximum 0.5 A continuous, 10VA (resistive load only)
Ethernet	RJ45
Data port	RS-232/422/485

Local storage	
Internal RAM	10 s pre-alarm recording
Memory card slot	Supports up to 32 GB microSDHC / 2 TB microSDXC card. (An SD card of Class 6 or higher is recommended for HD recording)
Recording	Continuous recording, ring recording, alarm/events/schedule recording

Network	
Protocols	IPv4, IPv6, UDP, TCP, HTTP, HTTPS, RTP/RTCP, IGMP V2/V3, ICMP, ICMPv6, RTSP, FTP, Telnet, ARP, DHCP, NTP (SNTP), SNMP (V1, MIB-II), 802.1x, DNS, DNSv6, DDNS (DynDNS.org, selfHOST.de, no-ip.com), SMTP, iSCSI, UPnP (SSDP), DiffServ (QoS), LLDP, SOAP, Dropbox, CHAP, digest authentication
Encryption	TLS 1.0, SSL, DES, 3DES, AES (optional)
Ethernet	10/100 Base-T, auto-sensing, half/full duplex
Connectivity	ONVIF Profile S, Auto-MDIX
Software	
Unit Configuration	Via web browser or Configuration Manager
Firmware update	Remotely programmable
Software viewer	Web browser, Bosch Video Client, or third party software
Optical	
Lens mount	CS mount (C-mount with adapter ring)
Lens connector	Standard 4-pin DC-iris connector
Focus control	Motorized back-focus adjustment
Iris control	Automatic iris control
Mechanical	
Dimensions (W x H x L)	78 x 66 x 140 mm (3.07 x 2.6 x 5.52 inch) without lens
Weight	855 g (1.88 lb) without lens
Color	RAL 9006 Metallic Titanium
Tripod Mount	Bottom and top 1/4-inch 20 UNC
Environmental	
Operating Temperature	-20°C to +50°C (-4°F to 122°F)
Storage Temperature	-30°C to +70°C (-22°F to +158°F)
Operating Humidity	20% to 93% RH
Storage Humidity	up to 98% RH

Ordering information

DINION IP starlight 8000 MP

High-performance 5MP box camera with exceptional low-light imaging. 5MP; PoE; iAE; iDNR; ROI (E-PTZ); IVA; H.264 quad-streaming; free viewing apps; cloud services; audio/motion detection

Order number **NBN-80052-BA**

Accessories

Varifocal SR Megapixel Lens

Varifocal SR megapixel IR corrected lens. 1/1.8" sensor; CS-mount; 4-pin SR-iris; 5MP; 4.1 to 9 mm; F1.6 to F5.2
Order number **LVF-5005C-S4109**

Monitor/DVR Cable SMB 0.3M

0.3 m (1 ft) analog cable, SMB (female) to BNC (female) to connect camera to coaxial cable.
Order number **NBN-MCSMB-03M**

Monitor/DVR Cable SMB 3.0M

3 m (9 ft) analog cable, SMB (female) to BNC (male) to connect camera to monitor or DVR.
Order number **NBN-MCSMB-30M**

UPA-1220-60 Power Supply

Power supply for camera. 120 VAC, 60 Hz In; 12 VDC, 1 A Out; regulated
Order number **UPA-1220-60**

UPA-1220-50 Power Supply

Power supply for camera. 220 VAC, 50 Hz In; 12 VDC, 1 A Out; regulated
Order number **UPA-1220-50**

Software Options

BVIP AES 128 Bit Encryption

Site licence for BVIP AES 128-bit encryption. Enables encrypted communication between BVIP devices and management stations
Order number **MVS-FENC-AES**

Represented by:

Americas:

Bosch Security Systems, Inc.
130 Perinton Parkway
Fairport, New York, 14450, USA
Phone: +1 800 289 0096
Fax: +1 585 223 9180
security.sales@us.bosch.com
www.boschsecurity.us

Europe, Middle East, Africa:

Bosch Security Systems B.V.
P.O. Box 80002
5617 BA Eindhoven, The Netherlands
Phone: + 31 40 2577 284
Fax: +31 40 2577 330
emea.securitysystems@bosch.com
www.boschsecurity.com

Asia-Pacific:

Robert Bosch (SEA) Pte Ltd, Security
Systems
11 Bishan Street 21
Singapore 573943
Phone: +65 6571 2808
Fax: +65 6571 2699
apr.securitysystems@bosch.com
www.boschsecurity.asia

China:

Bosch (Shanghai) Security Systems Ltd.
201 Building, No. 333 Fuquan Road
North IBP
Changning District, Shanghai
200335 China
Phone +86 21 22181111
Fax: +86 21 22182398
www.boschsecurity.com.cn

America Latina:

Robert Bosch Ltda Security Systems Division
Via Anhanguera, Km 98
CEP 13065-900
Campinas, Sao Paulo, Brazil
Phone: +55 19 2103 2860
Fax: +55 19 2103 2862
latam.boschsecurity@bosch.com
www.boschsecurity.com