

### Overview

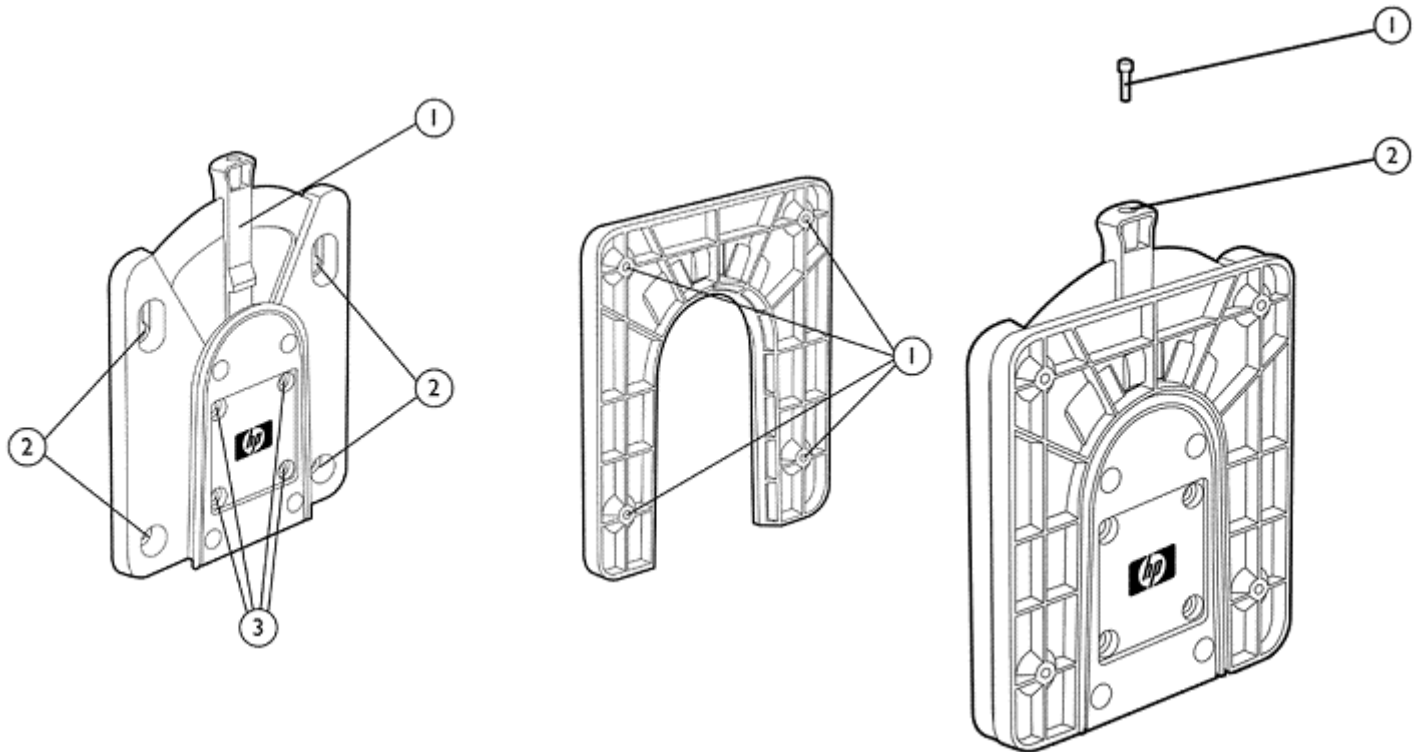

1. Release/locking
2. Four 100 mm VESA mount screw holes
3. Mounting holes for attachment to back of HP L2045w and Performance series monitor stands

1. Four 100 mm VESA mount screw holes

1. Locking pin screw
2. Locking pin hole on release/locking arm

### Models

Part Numbers:

HP Quick Release: EM870AA#ABA

### Introduction

HP offers a variety of optional products (each sold separately) designed to complement our monitors and enhance the overall computing experience. The HP LCD Monitor Quick Release is the newest option designed for use with 100 mm VESA-compatible flat panel monitors.

HP Quick Release is an easy to use, 100 mm VESA-compliant, LCD monitor mounting solution that allows you to quickly and securely attach a flat panel monitor to a variety of stands, brackets, arms or wall mounts. HP Quick Release can also be used for mounting any combination of devices that are compatible with the 100 mm VESA Flat Display Mounting Interface Standard. The failsafe "Sure-Lock" mechanism snaps the monitor (or mounted device) securely in place, and can be further secured with a theft-deterrent security screw.



### Overview

### Uniquely flexible product configurations

HP Quick Release enables uniquely flexible product configuration alternatives in a variety of settings, such as:

- Storefronts/kiosks: Mount flat panel monitors for easy viewing and add touchscreens for interactivity.
- Trade shows: Securely mount LCD TVs or monitors in common areas and quickly remove them for safekeeping at the end of the day.
- Front office environments: Minimize desk space requirements with wall or swing-arm mounting of monitors in reception areas.
- Training labs: Mount a monitor directly on a 100 mm VESA-compatible PC such as the HP Compaq 8200 Elite USDT or an HP Thin Client for all-in-one convenience.
- Medical/institutional settings: Securely mount monitors in nursing stations and public areas.
- Conference rooms: Mount projectors (with 100 mm VESA-compliant pre-drilled holes) on ceilings, and monitors on walls or tables.

### Compatibility

The HP LCD Monitor Quick Release is designed to integrate with select HP flat panel monitors, in configurations as noted below, as well as HP t5000 Series and the gt7725 Thin Clients or HP Compaq dc7900 or dc7800 or 8000 Elite USDT PC.

Compatible HP LCD monitor mounting scenarios	Direct mounting of monitor to wall	Direct mounting of monitor to mounting arm or bracket	Direct attachment of select thin client products or HP USDT to the back of monitor	Mounting of select thin client products or HP USDT between monitor and wall***	Mounting of select thin client products or HP USDT between monitor and mounting arm or bracket***
<b>ESSENTIAL SERIES</b>					
All Essential Series Products are compatible with the HP Quick Release	EM870AA*	EM870AA*	IWC stand (GN783AA)	EM870AA*	EM870AA*
LE1851wt (18.5-inch widescreen LCD)	EM870AA*	EM870AA*	IWC stand (GN783AA)	EM870AA*	EM870AA*
<b>ADVANTAGE SERIES</b>					
All Advantage Series Products are compatible with the HP Quick Release	EM870AA*	EM870AA*	IWC stand (GN783AA)	EM870AA*	EM870AA*
<b>Business Touchscreen Monitors</b>					
L2105 (21.5-inch diagonal 21.5-inch Widescreen LCD Touchscreen) Part #: EM891AA	EM870AA*	EM870AA*	IWC stand (GN783AA)	EM870AA*	EM870AA*
<b>PERFORMANCE SERIES - all products in this series ship with an HP Quick Release built into the stand</b>					
All Performance Series Products are compatible with the HP Quick Release except those listed below	EM870AA	EM870AA	EM870AA**	EM870AA	EM870AA
LP2475w (24-inch diagonal widescreen)	EM870AA	EM870AA	EM870AA**	Not available	Not available
LP2480zx (24-inch diagonal widescreen)	EM870AA	EM870AA	Not available	Not available	Not available



## Overview

LP3065 (30-inch diagonal widescreen)	EM870AA	Not available	Not available	Not available	Not available
	<p>*Requires removal of the monitor head from the monitor stand prior to mounting HP Quick Release.</p> <p>**Requires use of a second HP Quick Release attached to the base of the monitor stand.</p> <p>***Requires two separate Quick Release devices.</p>				
	<b>EM870AA</b>				
HP t5145 Thin Client	NK812AA#ABA, NK812AT#ABA				
HP t5325 Thin Client	VY623AA#ABA				
HP t5540 Thin Client	VA213AA#ABA, VA213AT#ABA				
HP t5545 Thin Client	VN134AA#ABA, VN134AT#ABA				
HP t5550, t5565, t5570 Thin Clients	XR246AA#ABA, XR248AA#ABA, XR250AA#ABA XR242AA#ABA, XR243AA#ABA				
HP t5630w Thin Client	VC069AA#ABA, VC069AT#ABA, VF212AA#ABA				
HP Compaq t5730 Thin Client	KD219AA#ABA KD219AT#ABA GY366AA#ABA GY227AA#ABA GY227AT#ABA GY367AA#ABA GY228AA#ABA KH995AA#ABA GY229AA#ABA GY230AA#ABA				
HP Compaq t5730w Thin Client	NV267AA NV267AT NZ489AA NV268AA NV268AT				
HP Compaq t5735 Thin Client	GY231AA#ABA, GY231AT#ABA GY368AA#ABA				
HP t5740, t5745 Thin Clients	VU899AA, VU900AA, VU902AA VU903AA, VU908AT				
HP gt7720 Thin Client	NG814AA, NG814AT				
HP gt7725 Thin Client	NG815AA, NG816AA				
Compatible PC					

## Service and Support

Your Option Limited Warranty is a one (1) year (HP Option Limited Warranty Period) parts replacement warranty on any HP-branded or Compaq-branded options (HP Options). If your HP Option is installed in an HP Hardware Product, HP may provide warranty service either for the HP Option Limited Warranty Period or the remaining Limited Warranty Period of the HP Hardware Product in which the HP Option is being installed, whichever period is the longer but not to exceed three (3) years from the date you purchased the HP Option.



### Technical specifications (EM870AA)

Mechanical	Dimensions (H x W x D)	Packaged:	7.8 x 6.25 x 1.5 in (19.8 x 15.9 x 3.8 cm)
		Unpackaged:	6.3 x 5.2 x 0.65 in (16 x 13.2 x 1.65 cm)
	Weight	Packaged:	1.1 lb (0.49 kg)
		Unpackaged:	0.82 lb (0.37 kg)
Additional components	<ul style="list-style-type: none"><li>• Eight 10 mm mounting screws (for attachment to VESA compliant monitor mounts)</li><li>• Eight 15.5 mm mounting screws (for attachment to HP thin client products)</li><li>• Four 20 mm mounting screws (for attachment to back of select HP flat panel monitor stands)</li><li>• One Quick Release "locking" screw</li></ul>		
Color	Carbonite		
Notes:	<ol style="list-style-type: none"><li>1. No HP monitors allow positioning of a thin client product between a monitor screen and its stand.</li><li>2. The Quick Release device is not to be used between a monitor screen and its stand unless provided that way from the factory.</li><li>3. Under no circumstances is the Quick Release device intended to be used in an orientation where the Release/Lock lever is oriented downward.</li></ol>		
Supported weight capacity	The HP Quick Release has been designed to support a maximum of up to 24 lbs (10.9 kg) depending upon the mounting configuration used. Please note this is a total weight limit for all devices mounted, i.e. the combined weight of the monitor and a second device such as an HP thin client product cannot exceed 24 pounds. Because mounting surfaces vary widely and the final mounting method and configuration may vary, mounting fasteners are not supplied (other than the VESA-compliant screws). HP recommends that you consult with a qualified engineering, architectural or construction professional to determine the appropriate type and quantity of mounting fasteners required for your application and to ensure that your mounting solution is properly installed to support applied loads.		

---

© 2009, 2010, 2011 Hewlett-Packard Development Company, L.P. HP shall not be liable for technical or editorial errors or omissions contained herein. The information is provided as is without warranty of any kind and is subject to change without notice. The warranties for HP products are set forth in the express limited warranty statements accompanying such products. Nothing herein should be construed as constituting an additional warranty. All performance specifications are provided by the component manufacturer. Performance specifications represent component manufacturer averages and actual performance may vary.

